

MineARC[®] Systems

Coal Mine Refuge (The CoalSAFE[®])

Designed to provide a long term refuge or 'safe-haven' for miners who become trapped or overwhelmed in a hazardous and/or toxic environment.

Coal Mine Change-Over-Station (COS)

Designed to provide a safe and secure area for miners to rest and change breathing apparatus as they step their way out of a hazardous and/or toxic environment.

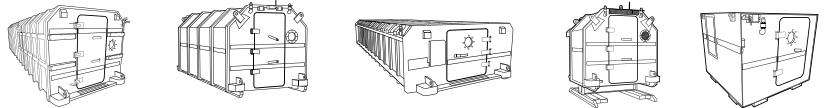

The world's leading manufacturer of emergency life saving refuge
Mining Safe. MineARC[®]

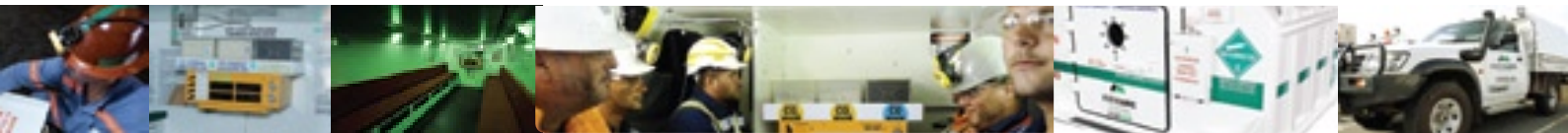

MineARC[®] COS
MineARC[®] CoalSAFE[®]

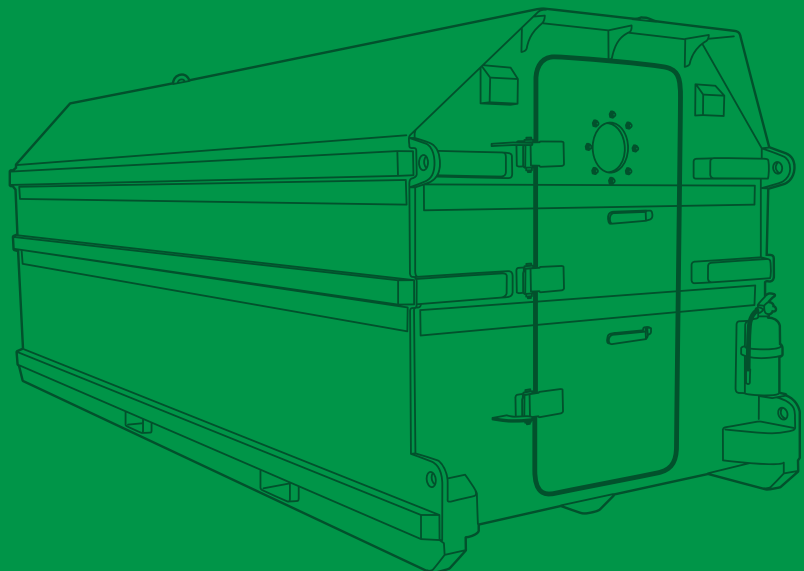



MineARC® Systems Company Profile

MineARC Systems is the global leader in the manufacture and supply of emergency safe-refuge to the underground mining, tunneling, and chemical processing industries.

With over 15 years experience in the industry, our dedication to ongoing research and development has kept us at the forefront of safe refuge technology. MineARC Refuges have been successfully used around the world in multiple mine and tunneling emergencies to save lives.

MineARC has offices and manufacturing facilities in Perth, Western Australia, Pretoria in South Africa, Santiago, Chile, Fushun in China and Dallas in the United States, as well as a strong distribution network worldwide.

MineARC manufactures refuges for operations in over 30 countries around the world. All MineARC Refuges comply with the highest international industry regulations and guidelines.

MineARC's CoalSAFE Refuge model is approved in the United States by the West Virginia Office of Miners' Health, Safety & Training and is built to the Mine Safety & Health Administration (MSHA) federal regulations '30 CFR Refuge Alternatives for Underground Coal Mines'.

MineARC CoalSAFE Refuges are also certified by the Chinese MA Centre for use in Chinese underground coal mines.

The CoalSAFE has been tested and refined with actual human testing. Multiple independent tests of the refuge's life support systems have verified that the CoalSAFE can successfully operate under a range of operating conditions.

MineARC is the only refuge manufacturer in the world with an ISO 9001 Quality Rating.

MineARC was a finalist in the 2010 Australian Exporter of the Year Awards.

www.minearc.com

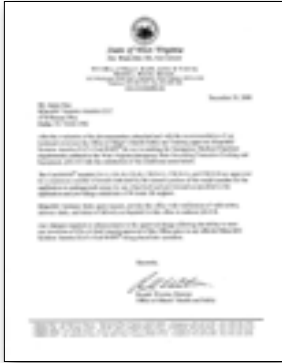

WV Office of Miners' Health, Safety & Training Approval



Built to MSHA 30 CFR Parts 7 and 75



IHSST, Inc. Independent Human Testing



WJE, Inc. Independent Blast and Structural Analysis and UL Testing



MineARC® Team Based Risk Assessment Testing



Bureau Veritas ISO 9001:2008 Quality Management Systems

Chinese MA Centre Certified



Why the Need for Refuge / Change-Over-Stations (COS) ?

Refuge chambers and change-over-stations form an integral part of an underground mine's wider Emergency Response Plan (ERP).

During an emergency situation, the first priority for all underground personnel should be to exit the mine via predetermined egresses and escape routes.

However, with some underground mine networks extending over a number of kilometers, exiting the mine can be a long and difficult journey. During which time personnel may be required to don breathing apparatus (self rescuers) which typically only provide up to 30 minutes of breathable oxygen supply.

In some emergencies personnel can easily become cut off and/or left simply unable to exit the mine. Fires, floods, rock-falls, explosions and the release of smoke and other forms of toxic gas (such as methane) can block escape routes and leave personnel injured or overwhelmed.

In these types of situations, when evacuating the mine is no longer safe or practical, emergency refuge is designed to provide a long-term safety option where personnel can gather and await extraction.

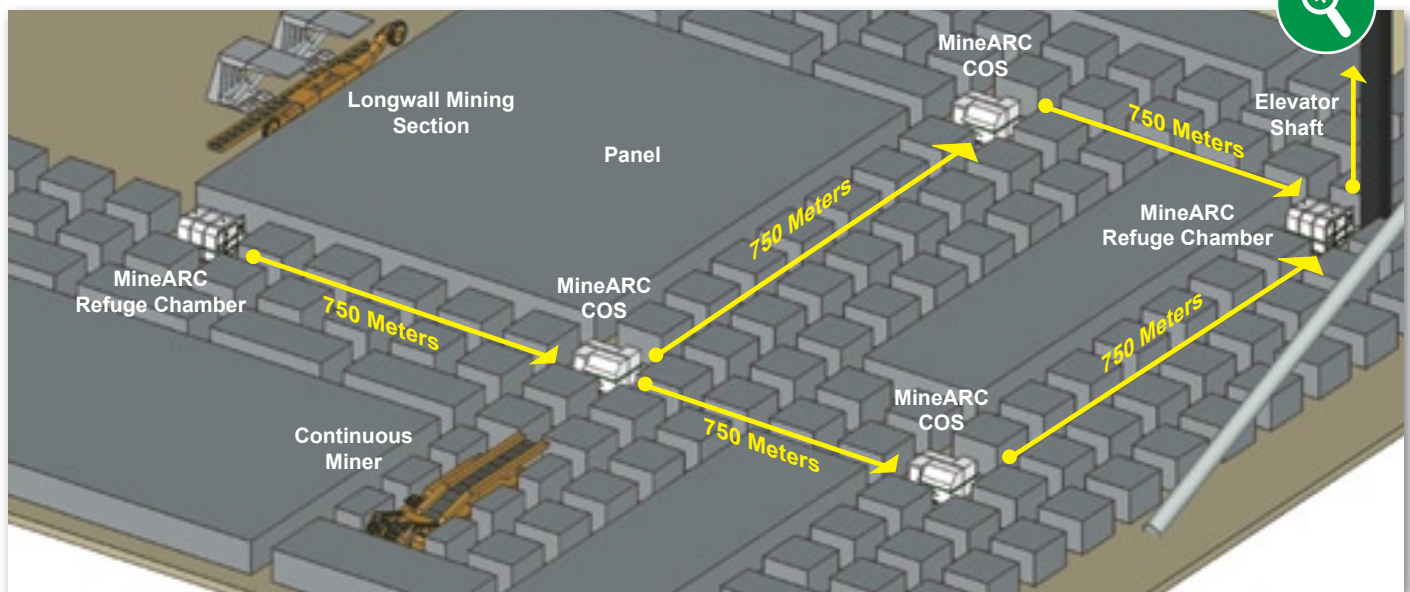
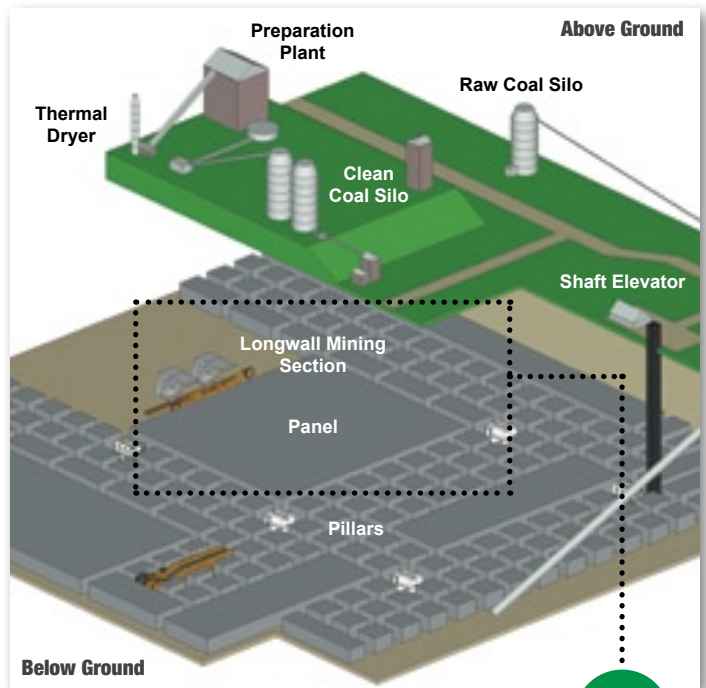

COS / Refuge Chamber Positioning

Change-Over-Stations and refuge chambers should be deployed throughout the mine to create a refuge 'network' accessible to all underground personnel whilst on foot. MineARC recommends that a combination of COS / refuge chambers be deployed near active workplaces, and at regular intervals throughout the mine – aiding personnel to 'step' their way out. Consistent with refuge legislation in Australia, China and the United States a safe distance of 750m between COS / refuge chambers is recommended.

This distance is based on the time it takes a person of reasonable fitness to consume 50% of the nominal duration of his/her self rescuer, walking at a moderate pace (approx 15 minutes). COS / refuge chamber requirements should therefore be calculated based on the:

- Size of the mine
- Provision/location of escape routes and egresses
- Number of active workplaces
- Number of personnel underground (including miners, supervisors, geologists etc).

MineARC® Standard CoalSAFE Refuge Chamber

MineARC® Systems designs and manufactures a range of models to suit different underground mines and mining conditions.

CoalSAFE® CS8 - CS16

In situations when evacuation is no-longer safe or practical, the CoalSAFE Refuge Chamber is designed to provide a long-term safety option where personnel can gather and await extraction.

MineARC CoalSAFE Refuge Chambers are blast proof to 15 PSI overpressure, can withstand primary and secondary blasts, extreme temperatures and flash fires, and can support life for several days standalone – even when cut off from mine air and power supply.

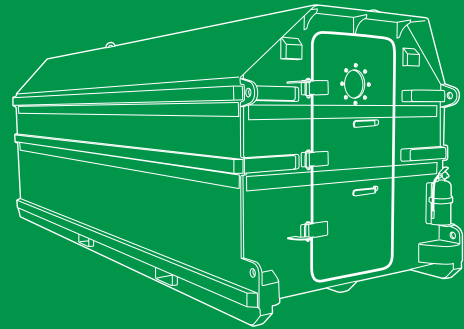

Model	Occupancy	Duration	Width	Height	Length
CS8	8	36	2300 mm (7'5")	2300 mm (7'5")	3945 mm (12'9")
CS12	12	36	2300 mm (7'5")	2300 mm (7'5")	5365 mm (17'6")
CS14	14	36	2300 mm (7'5")	2300 mm (7'5")	5665 mm (18'5")
CS16	16	36	2300 mm (7'5")	2300 mm (7'5")	7265 mm (23'8")

Above specifications based on 36hr duration model. Other durations available.





Construction

The CoalSAFE has been meticulously designed and engineered to ensure ease of transport and a robust design. Constructed from explosion resistant steel plate with internal support wraps and surround package as standard, the refuge can withstand in excess of 15 PSI (103kPa) overpressure with no permanent damage. The refuge's floor plate is constructed from 8mm (1/3") steel plate with tubular skids. Push points and towing and lifting eyes are provided top and bottom on front and rear.

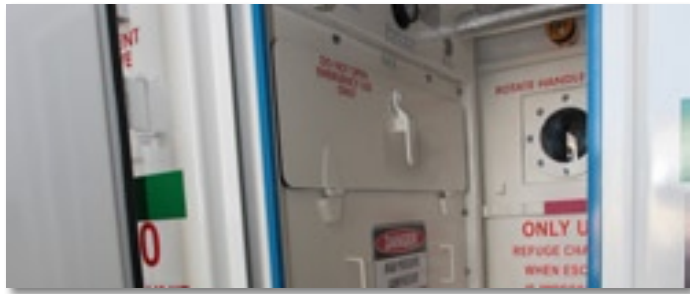

Airlock

The CoalSAFE features an integrated airlock system with automatic pneumatic flushing. On entering the refuge chamber's outer door an air curtain automatically activates to prevent ingress of smoke and other toxic gases. Once sealed inside the airlock compartment, a simple push-button activation system flushes the airlock in full.



Main Chamber

The CoalSAFE's internal chamber features durable high grade material seating on both sides, with ample under-seat, behind-seat and above-head storage for chemicals, PPE (Personal Protective Equipment), and self rescuers (SCSRs).

The CoalSAFE's internal walls are fitted with a thermal insulation barrier to help limit external heat transfer to the internal environment, and can withstand temperatures in excess of 200°C (350°F).



Service and Maintenance

MineARC CoalSAFE Refuges are easy to inspect and maintain, requiring minimal preventative maintenance. The CoalSAFE has a low ongoing cost of ownership with consumables having an extended shelf-life. MineARC Systems has a dedicated service team with the capacity to undertake all your servicing requirements as well as accredited training programs for customers to perform their own servicing.

Secure Cylinder Storage

High pressure cylinders used to power the CoalSAFE's life support systems are stored in separate cylinder compartments at the front of the refuge chamber.

With cylinders stored internally, operation of the refuge's life support systems can be performed entirely within the refuge chamber. Furthermore, all cylinders are housed inside the chamber's robust 15PSI blast rated structure.

Depending on the number of cylinders onboard, the CoalSAFE's life support systems can be maintained for up to 96hrs.





- ▶ **Intrinsically Safe**
- ▶ **CO & CO₂ Scrubbing**
- ▶ **Breathable Air**
- ▶ **Air Conditioning**
- ▶ **Flushing Airlock**
- ▶ **15 PSI Explosion Proof**
- ▶ **36/48 hrs Safe Entrapment**
(Optional 96 hrs)



Features Summary

MineARC® CoalSAFE® Refuge Chamber

STANDARD FEATURES

- ✓ Intrinsically Safe Design
- ✓ Breathable Air System
- ✓ Carbon Dioxide (CO₂) and Carbon Monoxide (CO) Scrubbing, and Moisture Removal
- ✓ Pre-Packaged Chemical Cartridges
- ✓ Powerless Cooling and Dehumidifying
- ✓ 36/48 Hours Minimum Life Support
- ✓ Push Button Airlock Flushing
- ✓ 15 PSI Explosion Proof
- ✓ Explosion Proof Ballistic Glass Viewing Portal
- ✓ Internal and External Gas Monitoring
- ✓ Secure Cylinder Storage Bays
- ✓ Fire Resistant Structure
- ✓ Communication Ports
- ✓ Ergonomic Designed Seating
- ✓ Surround Package (Reinforced Construction)
- ✓ Lifting and Towing Eyes
- ✓ Skid Base
- ✓ Chemical Toilet System

- ✓ Non-Slip Flooring
- ✓ Cyalume® Light Sticks
- ✓ Intrinsically Safe Long-Life Strobe
- ✓ Secure Internal Storage Area
- ✓ Reflective Signage

OPTIONAL FEATURES

- ✓ Intrinsically Safe Flashlight
- ✓ Fire Extinguisher
- ✓ Emergency Escape Hatch
- ✓ Fire Proof Structure
- ✓ Reinforced Attachment Points to Aid Maneuverability in Vertical Shafts
- ✓ First-Aid Kit

MineARC® Change-Over-Station

MineARC® Systems designs and manufactures a range of models to suit different underground mines and mining conditions.

Change-Over-Station COS / COS-CABA

The MineARC Change-Over-Station (COS) is designed to aid miners as they exit the mine; providing a safe and secure 'staging-post' stocked with self-rescuers SCSR's. A secondary model also houses a CABA quick fill station (COS-CABA).

Inside a MineARC COS, breathing apparatus can be changed over in safety, while personnel compose themselves and continue to plan their escape. Each COS features custom-designed storage to accommodate specific makes/models of breathing apparatus.

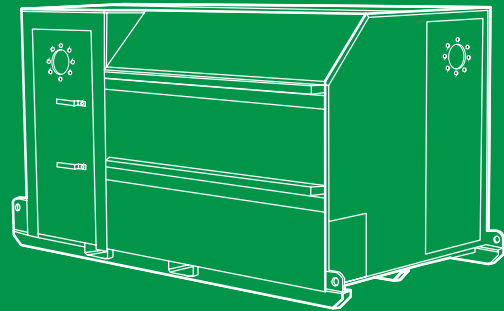

Model	Occupancy	Duration	Width	Height	Length
COS	n/a	n/a	2300 mm (7'5")	2300 mm (7'5")	3945 mm (12'7")
COS-CABA	n/a	n/a	2300 mm (7'5")	2300 mm (7'5")	4595 mm (15'1")

Custom models and specifications are available.

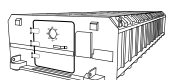



Construction

MineARC's Change-Over-Station (COS) has been designed and engineered to facilitate self-escape from the mine in the event of an emergency. Constructed from explosion resistant steel plate with internal support wraps and surround package as standard, the COS can withstand in excess of 15 PSI (103kPa) overpressure with no permanent damage. The COS's floor plate is constructed from 8mm (1/3") steel plate with tubular skids. Push points and towing/lifting eyes are provided top and bottom at front and rear. The COS is also fitted with an IT hitch (Integrated Transport) as standard, to aid maneuverability.



Entry / Exit Air-Locks

The 'walk-through' layout features a pneumatic flushing airlock compartment at both entrance and exit, as well as a main chamber area with seating space and ample self rescuer (SCSR) storage. On entering/exiting the COS an air curtain automatically activates to prevent ingress of smoke and other toxic gases. Once inside the airlock compartment, a simple push-button activation system flushes the airlock in full.



Main Chamber

The COS's internal chamber area features durable high grade material seating on both sides, with ample under-seat and above head storage. The internal walls are fitted with a thermal insulation barrier to help limit external heat transfer to the internal environment, and can withstand temperatures in excess of 200°C (350°F).

Inside the COS is a dedicated storage area housing up to 40 SCSR's (depending on model and duration). For CABA models an additional air cylinder storage compartment is located inside the COS, with 'quick fill' ports both inside and outside (meaning personnel can refill their breathing apparatus without having to enter the COS).



Service and Maintenance

The COS is easy to inspect and maintain, requiring minimal preventative maintenance. MineARC Systems has a dedicated service team with the capacity to undertake all your servicing requirements as well as accredited training programs for customers to perform their own servicing.

Secure Cylinder Storage

High pressure compressed air cylinders provide air supply to the main chamber area, CABA quick fill stations (if applicable) and power the entry/exit air lock systems. All cylinders are stored in a separate compartment at the COS's front entrance, housed safely inside the robust 15 PSI blast rated structure.





- ▶ **Intrinsically Safe Design**
- ▶ **Breathable Air Supply**
- ▶ **CO₂ Scrubbing** (Optional)
- ▶ **Flushing Airlock**
- ▶ **40+ SCSR Storage**
- ▶ **CABA Quick Fill Station** (Optional)
- ▶ **15 PSI** Explosion Proof



Features Summary

MineARC® Change-Over-Station (COS)

STANDARD FEATURES

- ✓ Intrinsically Safe Design
- ✓ Breathable Air Supply
- ✓ Push Button Airlock Flushing
- ✓ 15 PSI Explosion Proof
- ✓ Ample SCSR Storage (Self Contained Self Rescuer)
- ✓ Explosion Proof Ballistic Glass Viewing Portal
- ✓ IT Hitch
- ✓ Fire Resistant Structure
- ✓ Communication Ports
- ✓ Ergonomic Designed Seating
- ✓ Lifting and Towing Eyes
- ✓ Non-Slip Flooring
- ✓ Cyalume® Light Sticks
- ✓ Intrinsically Safe Long-Life Strobe
- ✓ Secure Internal Storage Area
- ✓ Reflective Signage

OPTIONAL FEATURES

- ✓ CABA Quick-Fill Station (Compressed Air Breathing Apparatus)
- ✓ CO₂ Scrubbing
- ✓ Emergency Escape Hatch
- ✓ Fire Proof Structure
- ✓ Intrinsically Safe Flashlight
- ✓ Fire Extinguisher
- ✓ First-Aid Kit
- ✓ Air Operated CO₂ Scrubber

Through innovative design, the CoalSAFE provides both a powerless carbon dioxide / carbon monoxide scrubber, as well as a powerless air conditioning system - The MARCis® (MineARC Air Refuge Chamber intrinsically safe).

The MARCis®

Carbon Dioxide & Carbon Monoxide Scrubbing

MineARC's patented carbon dioxide (CO₂) and carbon monoxide (CO) scrubbing system requires no electrical power to operate. The active chemical scrubbing system is designed to clean the air of these harmful gases and toxins that build up over time within a sealed, occupied environment. MineARC developed the technology to provide the occupants with ease of use and extended time periods between chemical change outs.

MARCISORB CO₂ and CO chemical cartridges provide proven chemical scrubbing capabilities and are easy to handle. Sealed in a barrier film bag, the cartridges will store efficiently for long periods of time without degradation or requiring any maintenance.

Intrinsically Safe Air-Conditioning

Independent testing has verified that a cooling system is essential for combating the potentially fatal effects of metabolic heat buildup inside the refuge. To maintain the internal atmosphere of the CoalSAFE, the MARCis incorporates a non electrical air conditioning system that both cools and dehumidifies the refuge.

US and Chinese industry regulators state that refuge manufacturers must specify the maximum mine air temperature under which the refuge is designed to operate when fully occupied, whilst maintaining an internal apparent temperature of 95°F. The CoalSAFE has been successfully tested in ambient external temperatures above 80°F.

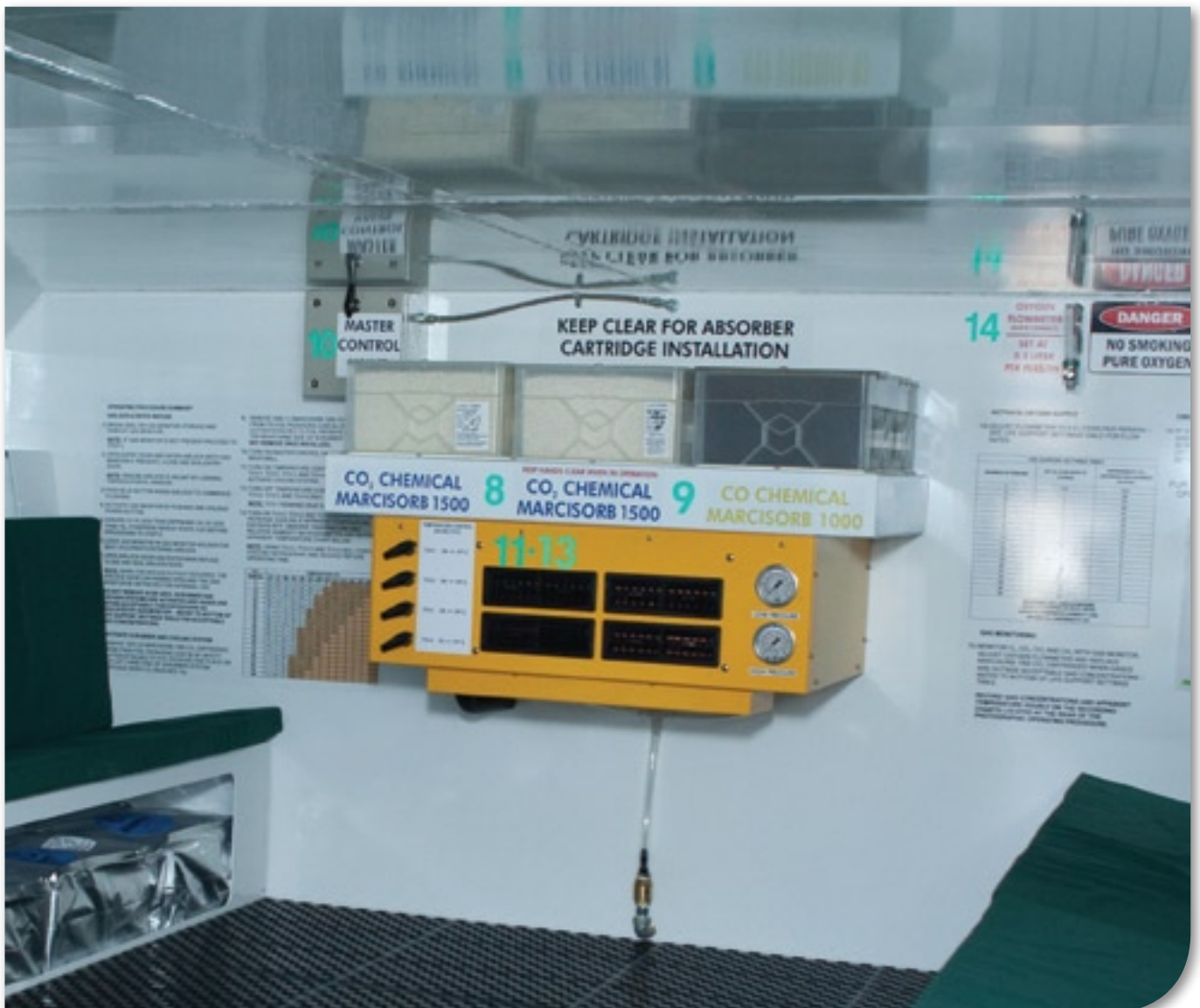



Operating Procedure

The CoalSAFE Refuge is uncomplicated and fast to operate in an emergency. Utilizing a sequential numeric operating procedure, the refuge's life support systems can be activated in less than 60 seconds.

MineARC's comprehensive operational and maintenance train-the-trainer program includes hands on training as well as virtual reality software. This ensures optimal use of training time and maximum retention.

VR Training Software

Working in tandem with traditional training techniques, our custom made training software adds another dimension to user proficiency.

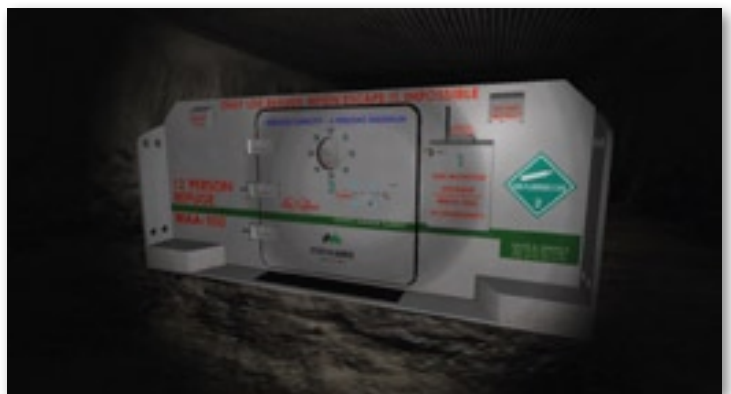



MineARC® NORTH AMERICA

4730 Bronze Way, Dallas, Texas 75236
ph: +1 (214) 337 5100
fax: +1 (214) 337 5103
email: info@minearc.com

MineARC® EUROPE

B30, 1E Vila Sol
8125-307 Vilamoura, Portugal
ph: +351 91 616 7664
fax: +351 289 322 308
email: matt.schlapfer@minearc.com.au

MineARC® CHINA

ph: +61 (8) 9333 4966
email: info@minearc.com.au

MineARC® SOUTH AMERICA

Rosario Norte 615, of. 2001 Piso 20
Las Condes Santiago, Chile
ph: +56 2 9644290
fax: +56 2 9644291
email: info@minearc.com

MineARC® AFRICA

Owen Georgiou
PO Box 1065 Lanseria, 1758
South Africa
ph: +27 86 111 4266
mob: +27 (0) 83 271 6771
email: owen.georgiou@minearc.com

HEAD OFFICE

MineARC® AUSTRALASIA

274 Welshpool Road, Perth, 6106
ph: +61 (8) 9333 4966
fax: +61 (8) 9333 4900
email: info@minearc.com.au

www.minearc.com

